

Amphenol®

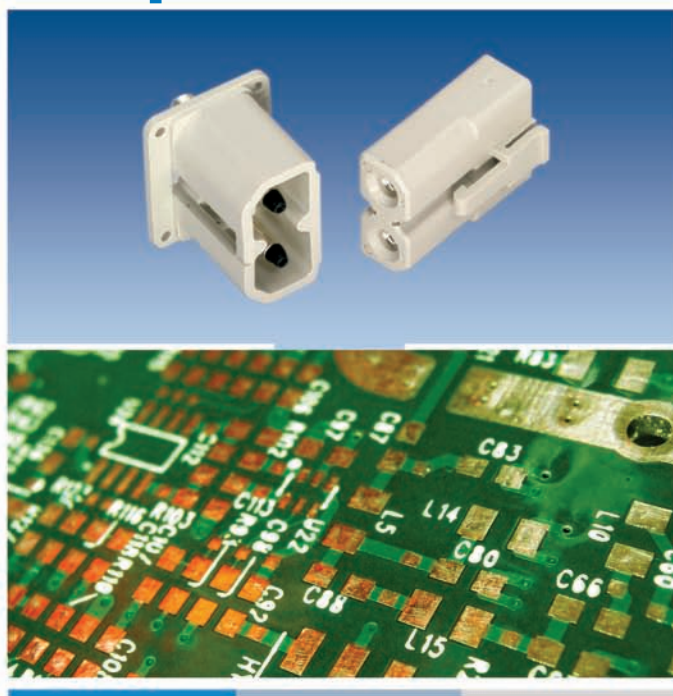

Amphenol® RADSOK® Power Bus Amphe-PD™ Connectors

Amphenol® Industrial Operations now introduces its Amphe-PD™ connector series. The Amphe-PD™ series features RADSOK® technology, a terminal that features a stamped hyperbolic grid providing low insertion force, high amperage, high reliability, and a longer cycle life. The Amphe-PD™ connector series is ideally suited for the datacom industry, as well as many other applications.

The Amphe-PD™ connectors generate more processing power with less heat than a similar-sized connector. The series produces greater amperage without wasting valuable space, offering a compact solution for datacom applications, which require small, yet powerful connectors.

The Amphe-PD™ solution is UL listed at 69A and CSA listed at 55A. Amphe-PD™ features a single position RADSOK® with molded socket shell or a dual-position TUV “touch-proof” with a V0 rating. In addition, the RADSOK® in the Amphe-PD™ supports a 50A to 70A continuous duty rating. Amphenol’s Amphe-PD™ series was developed with the ability to connect to wires, busbars, as well as circuit boards. This flexibility allows the Amphe-PD™ to be used in a wide variety of applications. Several different plastic receptacle-mounting variations are also available.

In addition to the two position, 3.6mm RADSOK® rated at 55A, Amphenol now has introduced a two position 5.7mm version capable of carrying 120A continuously. This design has crimp contacts in the plug and receptacle with a crimp barrel for 4 awg wire. Contact Amphenol for more product details.

With millions of parts in the field, the RADSOK® electrical connection has proven to be extremely stable, with almost no reported connection failures in Amphenol-RADSOK®-designed applications. RADSOK® utilizes the tensile strength properties of the flat, high conductivity alloy grid for the high normal forces required for conductivity, while providing a large conductive surface area. This results in a correspondingly low voltage drop and low temperature rise while maintaining low insertion forces.

Additional benefits of the Amphe-PD™ product include:

- Low cost, 100% molded housings
- Integrated latching mechanism
- Easy, Tool-less assembly
- Low Insertion Force
- High Reliability
- High Cycle Durability
- High Ampacity
- Tactile and audible locking
- Proven metal clip contact retention on receptacles
- TPA device on plug to insure socket locking

Technical Specifications: UL rated 69 amps (6 AWG). CSA rated 55 Amps (6 AWG). Molded from UL94V-0 thermoplastic (self extinguishing). Meets RoHS and UL-94V-0 guidelines. 2-pole DC Power interconnect in about 1 square inch. Passes UL and TUV finger proof design standards.

Plug

10-638974-000 3.6mm RADSOK® Plug

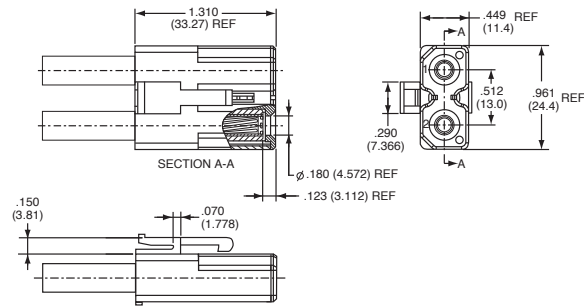

Receptacles

10-638975-000 Busbar Receptacle

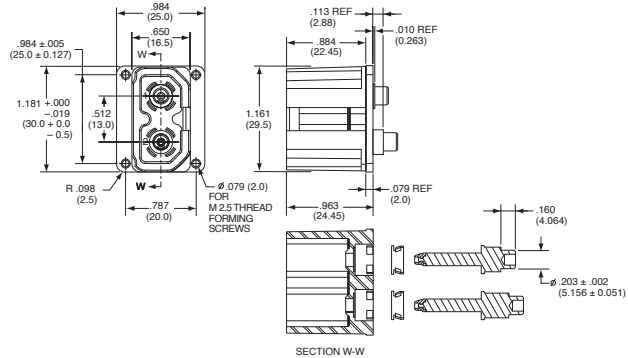

10-638976-000 Busbar Receptacle

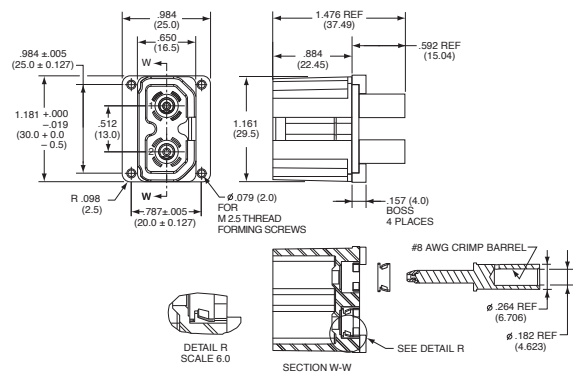

10-638977-000 PCB Tail Receptacle

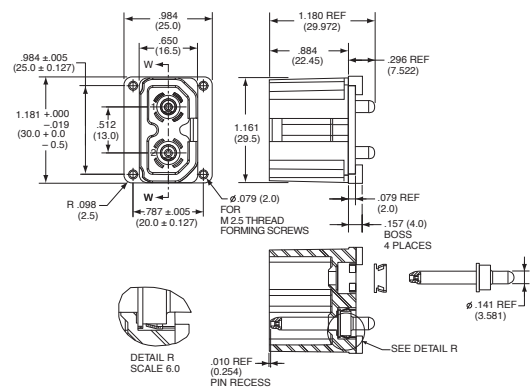

Notice: Specifications are subject to change without notice. Contact your nearest Amphenol Corporation Sales Office for the latest specifications. All statements, information and data given herein are believed to be accurate and reliable but are presented without guarantee, warranty, or responsibility of any kind, expressed or implied. Statements of suggestions concerning possible use of our products are made without representation or warranty that any such use is free of patent infringement and are not recommendations to infringe any patent. The user should assume that all safety measures are indicated or that other measures may not be required. Specifications are typical and may not apply to all connectors.

For further information on your individual application requirements, contact: Amphenol Corporation

North America:
Amphenol Industrial Operations
180 N. Freeport Drive, Plant 4
Nogales, AZ 85621
Tel: (520) 285-5130
Fax: (520) 285-5134

Europe:
Amphenol Industrial Operations Europe
Via Barbaiana 5
1-20020 Lainate (MI) Italy
Tel: +39 02 93254.204
Fax: +39 02 93254.444

Middle East:
Amphenol Middle East Enterprises FZE
Office C-37 PO Box 21107
Ajman Free Zone, UAE
Tel: +9716-7422494
Fax: +9716-7422941

Asia:
Amphenol Technology Shenzhen Ltd
Block 5 Fuan 2nd Industrial Park
Dayang Rd, Fuyong Baoan
Baoan, Shenzhen, China 518103
Tel: +86 755 2881 8389
Fax: +86 755 2991 8310
Email: enquiry@amphenol-aio.com

Email: rpedrazzini@amphenol-aio.com

Email: info@amphenol-aio.com

Email: ameeffe@eim.ae